

Nema 17 Stepper Motor

Rev: A

Date:

COMMON RATINGS

Step angle :	1.8°	Dielectric strength :	500VAC
Positional accuracy :	±5%	Insulation resistance :	100Mohm(500VDC)
Number of Phase :	2	Ambient Temperature :	-10°C~50°C
Temperature rise :	80°C MAX	Insulation class :	B
Rotor Inertia :	20gcm ²	Weight :	0.18Kg

SPECIFICATIONS

Holding Torque (2 phases on) Kg.cm	Rated Current/Phase (Amps DC)	Phase Resistance (ohms) ±10%	Voltage Current/Phase (V DC)	Phase Inductance (mH)±20%(1KHz) Typical
1.8	0.7	4.2	2.9	5.5

DIMENSIONS unit=mm

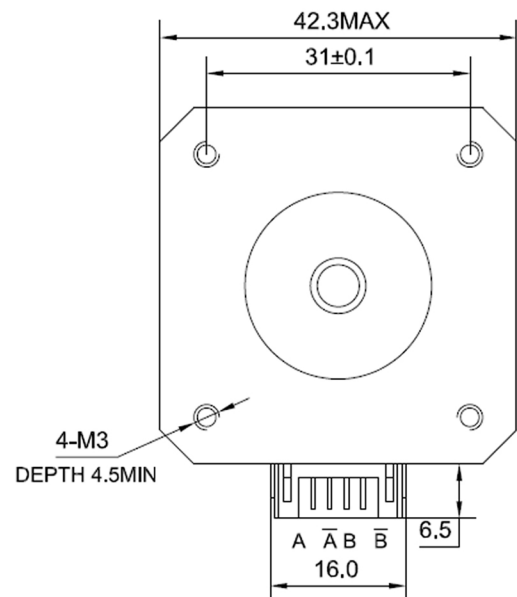
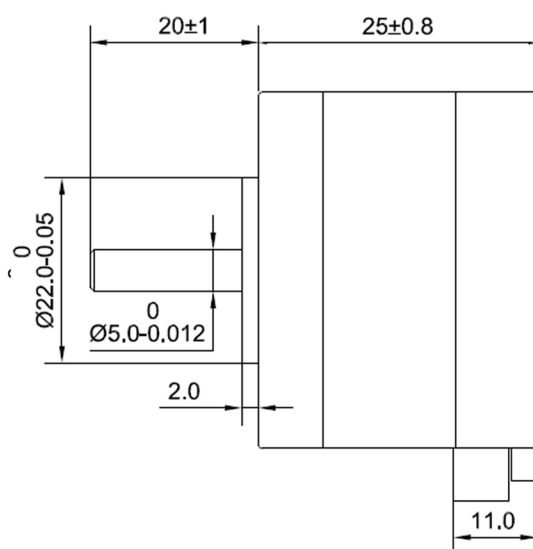

CONNECTIONS

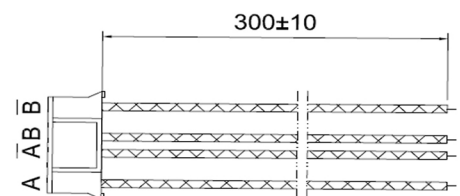
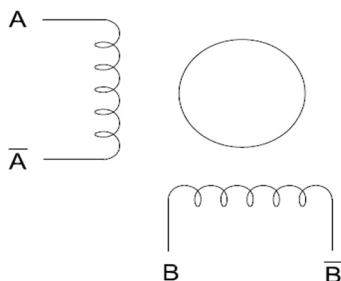

130003



BONDTECH